

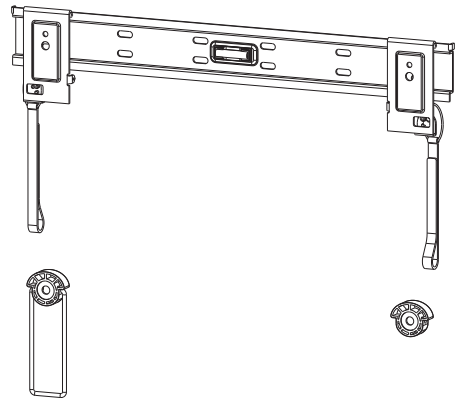















Brugsanvisning

 Maks. belastning 50 kg.



(A)	 x4	(B)	 x4	(C)	 x4	(D)	 x4	(E)	 x4	(F)	 x4	(G)	 x4	(H)	 x4
(I)	 x6	(J)	 x6	(K)	 x2	(L)	 x6	(M)	 x2	(N)	 x4	(O)	 x4	(H)	 x4
	M4x14		M5x14		M6x14		M4x30		M5x30		M6x30		M8x14		M8x30
	Ø10x50		M6.3x55		D5		D6		D8		12x6x13		15x8.2x15		M8x30

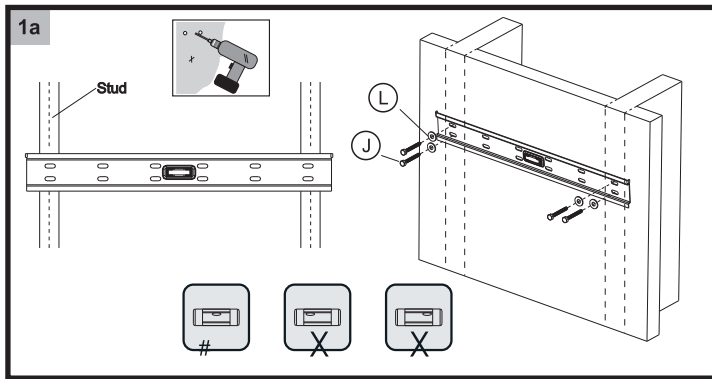

OBS: Vi anbefaler at efterrække med eksternt vaterpas

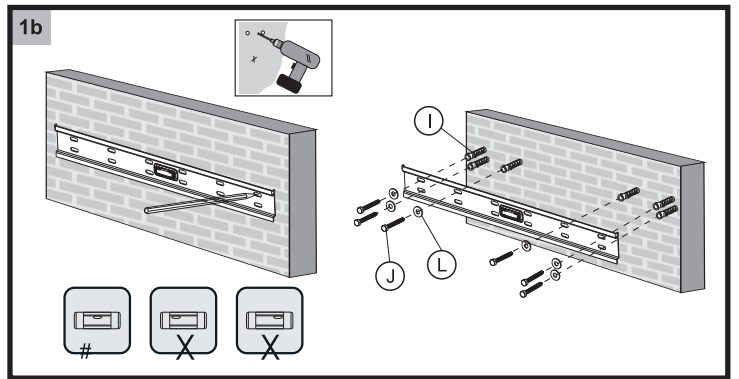

OBS: Vi anbefaler at efterrække med eksternt vaterpas

